



Guangzhou Star River
Guangzhou, China



Elite Tower
Dubai, UAE



ITC Gardenia
Bangalore, India

2016/09



AluK Building Systems Private Limited

Bagmane Laurel, "B" Block, 2nd Floor, Level 3
Bagmane Tech Park, CV Raman Nagar
Bangalore-560093, Karnataka, India

T: +91 80 3304 3304
E: info@aluk.in

aluk.in

ALUK[®]

SC95

SLIDING DOOR SYSTEMS

ALUK[®]

SC95 : SLIDING SYSTEMS WINDOWS & DOORS

The SC95 sliding window and door system from AluK is a superior, high performing sliding solution with aesthetics and design appeal. The product comes with sturdy rollers tested for many cycles of operation and a trusted and proven AluK product worldwide for decades. This versatile sliding window solution comes with lot of choices and customized options and is an ideal lifetime sliding solution for tropical and hot climate applications in high-rise buildings, individual residences and commercial establishments.

Product features

- SC95 sliding system is based on non-insulated profiles. The thermal break insulated profile option is available in SC95TT.
- A 95 mm frame in two track and 143 mm frame in three track, single and double glazed slider with 85 mm interlock profile at centre. Slimmer option of 55 mm interlock is also available.
- SC95 comes with a glazing bead based solution; hence convenience in glass interchangeability for users.
- Superior aesthetics with international design appeal: 45 degree join for sashes and 90 degree join for frames.
- Well-designed sloped bottom track with effective drainage solution.
- Anodized rail on bottom track for extra smooth sliding.
- Solid and robust in performance works for very high design wind pressure; a thoroughly tested window system for demanding weather criteria of tropical zones. A tested and certified product as per EN norms for air/water/wind.
- Possibility of fixed light, flyscreen/casement integration.
- All accessories, fittings, gaskets are AluK branded and tested for performance.
- Value added features like perimeter gasket for added protection at edges of the window application surface.
- Single, multipoint locking with flush spring locks, thumb pull lever locks or cremone handles for convenience of usage.
- This system is adapted for large dimensions with sash weight up to 160 kg of load bearing capacity per sash.
- Infill glass can be single or double glazed (thickness can vary from 6 to 24 mm).



Performances

- $U_w = 2 \text{ W/m}^2\text{K}$ (SC95TT)
- Air: 4
- Water: 8A
- Wind: B2

Test based on a window of 2 Track 2 Sashes of W 2392 mm and H 2290 mm.

	SC95	SC95TT
SYSTEM FEATURES		
Standard Dimensions (mm)	H 2400 mm x W 2000 mm	H 2400 mm x W 2000 mm
Max Sash Weight (kg) (max)	160 kg	160 kg
Options	Low threshold (for disabled people) Fixed and sliding sash window Flyscreen	Low threshold (for disabled people) Fixed and sliding sash window Flyscreen
Dual Colour Option	-	•
Multi-Point Locking	•	•
Glazing Thickness	6 mm - 24 mm	20 mm - 24 mm

Product configuration

- Available in 2 track and 3 track sliding option with 2/3/4/6 panels.
- Reinforcement interlock option for higher structural stability cases.
- 95 mm bottom track width for 2 track windows and 143 mm width for 3 track windows with 54 mm track height.
- Same horizontal and vertical shutter sections connected at 45° at corners for better aesthetics.
- Mosquito mesh as an add-on attachment option as well as integrated in sashes.
- Single & multi point locking option for better security and stability of the window.

Innovative product composition options

- Slim interlock: gives more vision per panel at centre yet having strong and stable in performance.
- Fixed composition in frame: cost-effective and more vision solution for fixed light windows. No need for sash frames; the composition takes care of the desired solution in the frame itself; light on weight, less in material consumption yet giving the desired performance with smart design intent.
- Balustrade integration: inbuilt railing solution for sliding windows - a break through solution for optimum space management by integrating the balustrade within the window frame.

Applications

- 2 Track 2 Sashes
- 2 Track 3 Sashes
- 3 Track 4 Sashes
- 3 Track 6 Sashes
- Fixed lights in combination with sliding sashes

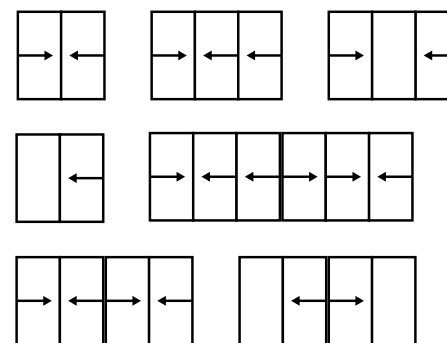

New generation of accessories

- Rollers: made with reinforced polyamide with POM wheels to reach up to 160 kg with two double rollers. Conform to standard EN 13.126-15.
- Recessed handle: a new range offering different types of recessed handles for balcony doors and windows.
- Single/multi locks: face-plate locks declinable in 1, 2 or 3 locking points, easy to install thanks to a specific adaptor on the profile.
- AluK branded counterplate: equipped with one clamp to ensure easy and quick installation. Can be coloured into any RAL colours.
- Handles: a variety of new designs customisable in any colour.

CAD cross sections and thermal profile

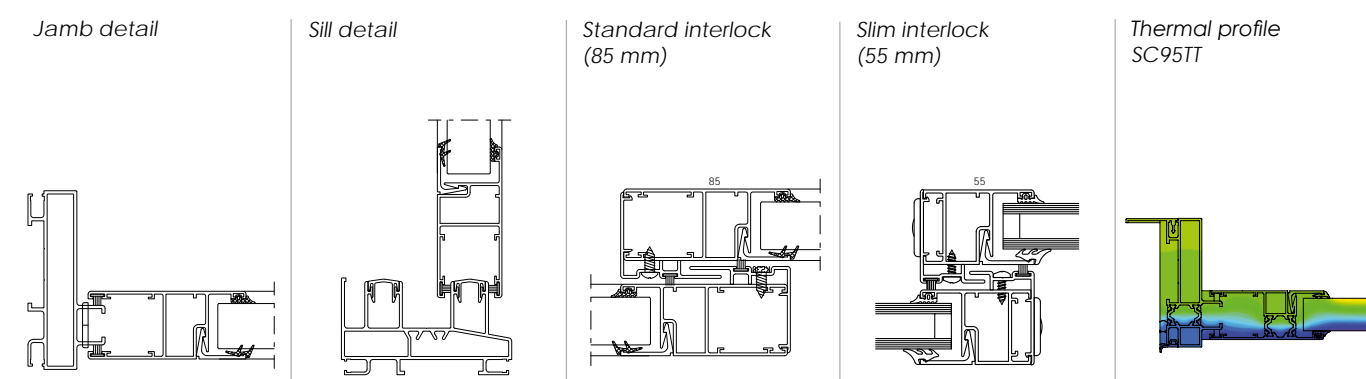

The Fairmont Palm Hotel and Resort
Palm Jumeirah, UAE

